

NASH VectraPaks

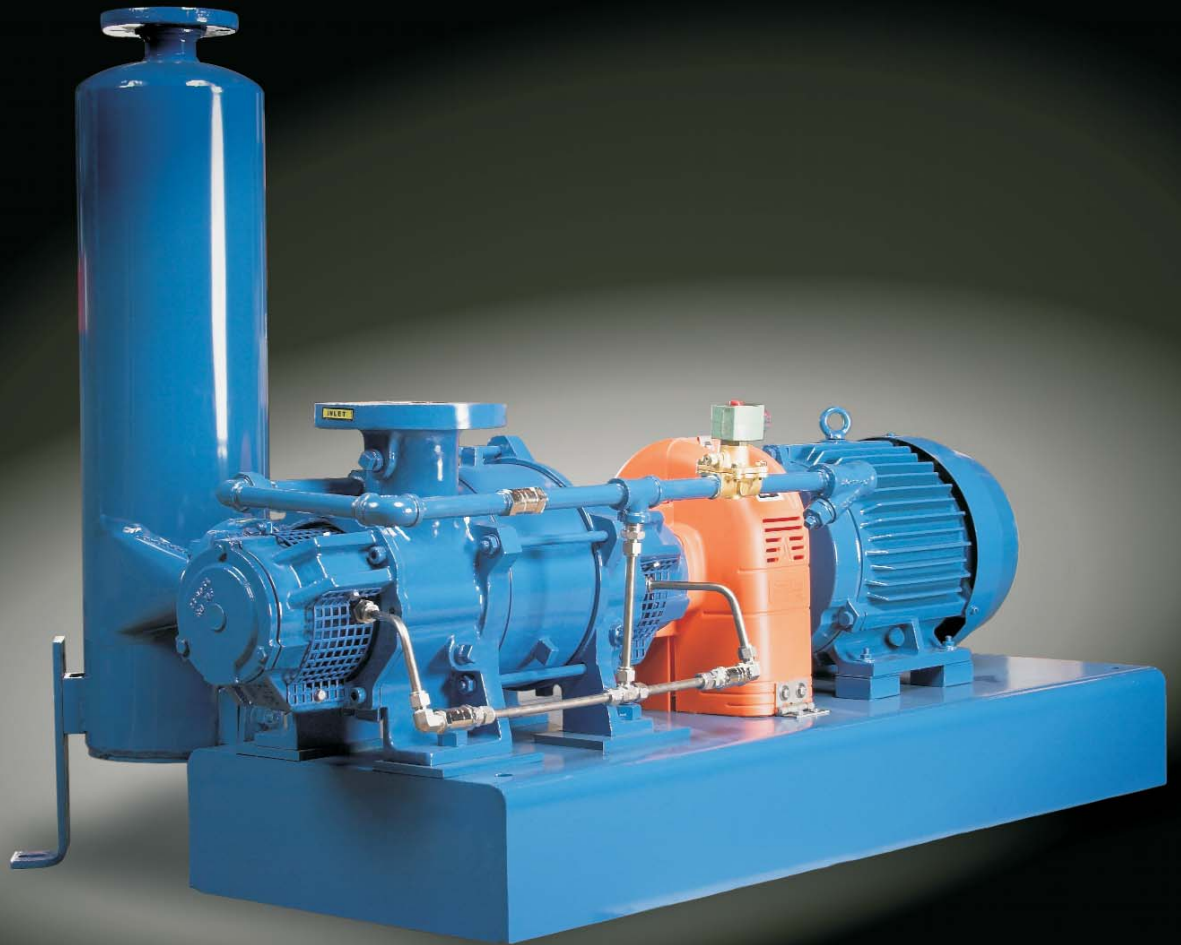

NASH VectraPaks - Standardized Solutions

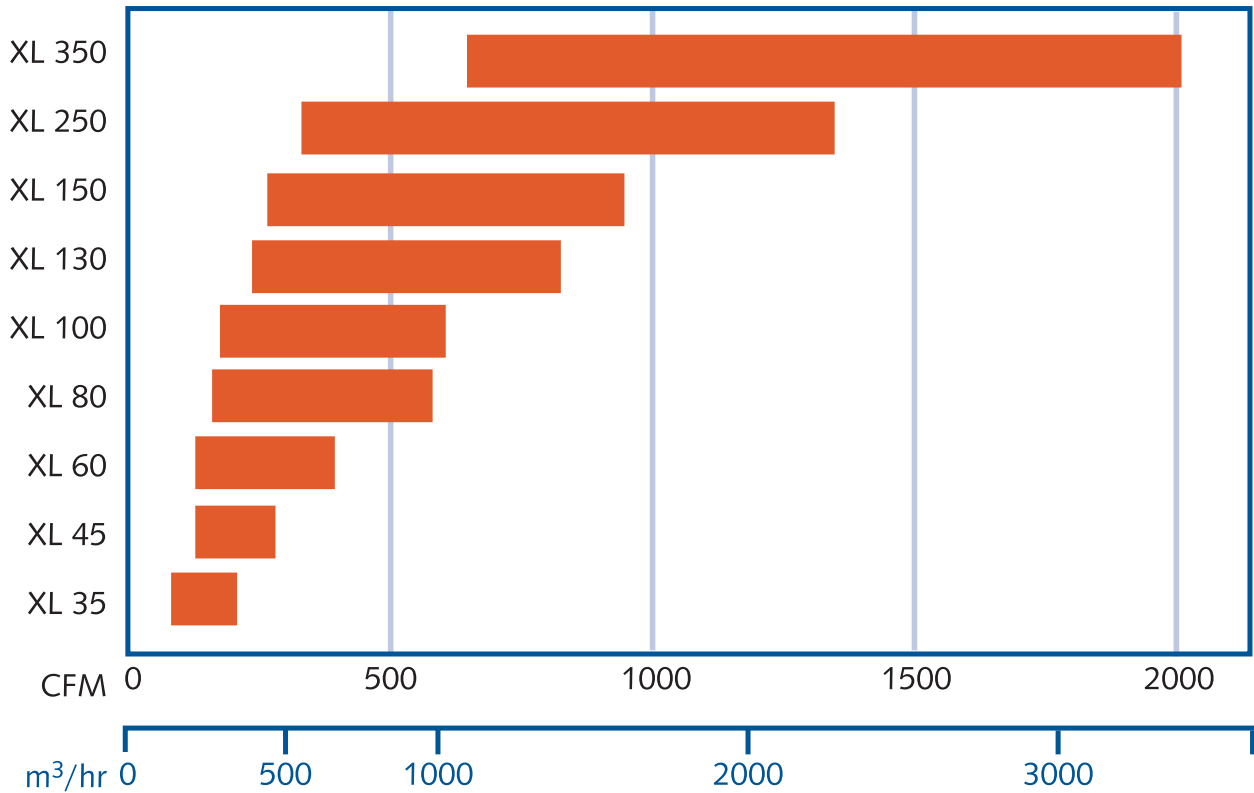

Vectra Feature	Benefits
External mechanical seals	Flexibility and ease of maintenance
Direct drive speeds for 50/60 Hz motors	For worldwide use
Extended pressure ratings	Ability to handle tough applications where backpressure is required
Conical design	Better ability to handle water/particulate slugs and residual gases
One moving part	Long term reliability
Variable port design	High efficiency
Patented gas scavenging	Increased performance at high vacuum levels
Factory performance tested	Trouble free start-up and operation
Backed by 2 year warranty and over 100 years of vacuum and compressed gas experience	Peace of mind

NASH VectraPaks - Direct Drive Dimensions

Options	Once-Through	Recirc.
High vacuum flow controls	X	X
Inlet check valve	X	X
Inlet isolation valve	X	X
External lobe purge	X	X
Mechanical seals (standard or stainless steel)	X	X
Relief valve	X	X
Vacuum gauge	X	X
Flow switch	X	
Partial recirculated seal	X	
Seal line isolation valve	X	
Spray nozzle	X	
Variable speed drive	X	X
Motor enclosures: • ODP • TEFC (standard) • TEFC-SD • Explosion proof	X	X
Motor efficiency: • EISA (standard)	X	X
Motor voltages: • 230/460 (standard) • 575	X	X

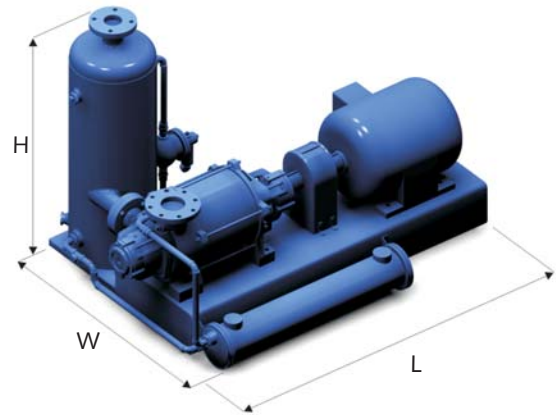

Once-Through Systems

Model	L in • mm	W in • mm	H in • mm	Inlet in • mm	Discharge in • mm	Weight lb • kg
XL 35	49 1245	35 889	38 965	3 76	2 51	637 289
XL 45	57 1448	35 889	38 965	3 76	2 51	750 340
XL 60	64 1626	40 1016	47 1194	4 102	3 76	1161 527
XL 80	70 1778	40 1016	47 1194	4 102	3 76	1326 601
XL 100	73 1854	45 1143	54 1372	4 102	4 102	1640 744
XL 130	80 2032	45 1143	54 1372	4 102	4 102	1858 843
XL 150	81 2057	48 1219	54 1372	6 152	4 102	2174 986
XL 250	94 2388	59 1499	76 1930	6 152	6 152	3393 1539

Recirculated Systems

Model	L in • mm	W in • mm	H in • mm	Inlet in • mm	Discharge in • mm	Weight lb • kg
XL 35	49 1245	45 1143	30 762	3 76	2 51	800 363
XL 45	57 1448	45 1143	30 762	3 76	2 51	913 414
XL 60	64 1626	50 1270	47 1194	4 102	3 76	1348 611
XL 80	70 1778	50 1270	47 1194	4 102	3 76	1513 686
XL 100	73 1854	57 1447	59 1499	4 102	4 102	1800 816
XL 130	80 2032	57 1447	59 1499	4 102	4 102	2018 915
XL 150	81 2057	59 1498	59 1499	6 152	4 102	2384 1081
XL 250	94 2388	60 1524	63 1600	6 152	6 152	3632 1647

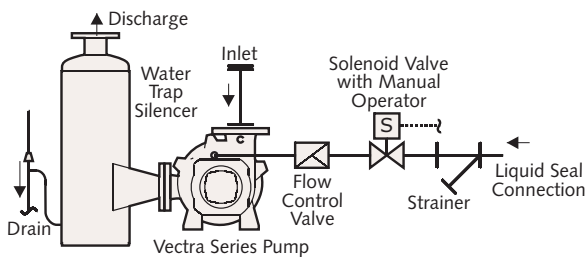

Once-Through System

Applies to Both
Direct and V-Belt Drive Systems

NASH VectraPaks - V-Belt Drive Dimensions

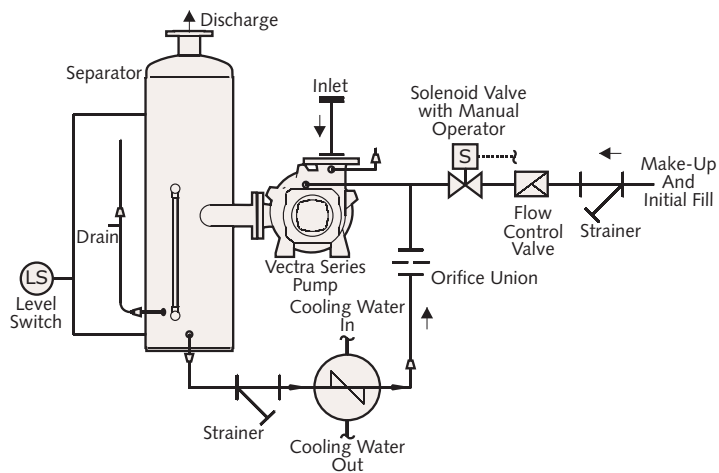
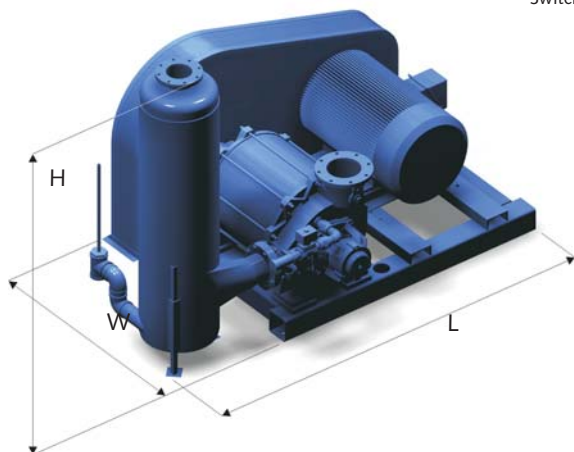

Recirculated System

Applies to Both
Direct and V-Belt Drive Systems

Once-Through Systems

Model	L in • mm	W in • mm	H in • mm	Inlet in • mm	Discharge in • mm	Weight lb • kg
XL 35	61 1549	50 1270	38 965	3 76	2 51	674 306
XL 45	61 1549	50 1270	38 965	3 76	2 51	696 316
XL 60	66 1676	56 1422	47 1194	4 102	3 76	1115 506
XL 80	66 1676	56 1422	47 1194	4 102	3 76	1265 574
XL 100	78 1981	59 1473	54 1372	4 102	4 102	1670 758

Model	L in • mm	W in • mm	H in • mm	Inlet in • mm	Discharge in • mm	Weight lb • kg
XL 130	78 1981	63 1600	54 1372	4 102	4 102	1862 845
XL 150	92 2337	70 1778	54 1372	6 152	4 102	2152 845
XL 250	101 2565	82 2083	76 1930	6 152	6 152	3044 1381
XL 350	112 2845	96 2438	78 1981	8 203	6 152	5075 2302

Recirculated Systems

Model	L in • mm	W in • mm	H in • mm	Inlet in • mm	Discharge in • mm	Weight lb • kg
XL 35	66 1676	50 1270	37 940	3 76	2 51	837 380
XL 45	66 1676	50 1270	37 940	3 76	2 51	859 390
XL 60	71 1803	56 1422	45 1143	4 102	3 76	1302 591
XL 80	71 1803	56 1422	45 1143	4 102	3 76	1452 659
XL 100	84 2134	59 1473	59 1499	4 102	4 102	1830 830

Model	L in • mm	W in • mm	H in • mm	Inlet in • mm	Discharge in • mm	Weight lb • kg
XL 130	84 2134	63 1600	59 1499	4 102	4 102	2022 917
XL 150	99 2515	70 1778	59 1499	6 152	4 102	2362 1071
XL 250	99 2515	82 2083	63 1600	6 152	6 152	3283 1489
XL 350	121 3073	96 2438	70 1778	8 203	6 152	5549 2517

NASH VectraPaks - Standardized Solutions

- **Pre-engineered**
- **Quick delivery**
- **Plug & Play**
- **Available in Iron and Stainless Steel**

Simplify your installation with a packaged system from Gardner Denver Nash. Pre-engineered NASH VectraPaks are provided with all of the necessary components assembled and piped. You receive a complete system that is ready to install.

Mounted pumps, once-through and fully recirculated systems are available in various sizes, and in iron or all stainless steel construction.

Vacuum levels to 29" HgV (to 31 mbar abs).

Need higher vacuum? We also offer Oil Sealed packages. Contact us for further details.



	Mounted Pumps	Once-Through Packages	Recirculated Packages
Use When...	...replacing an existing system or where accessories can be reused	...contamination is not a problem and the supply of seal liquid is plentiful	...liquids and gases are hazardous or toxic and where contamination is a concern
Benefits	<ul style="list-style-type: none"> • Lowest initial cost 	<ul style="list-style-type: none"> • Simplicity • Low initial cost 	<ul style="list-style-type: none"> • Low water consumption • Condensable inlet gases may be recovered • Seal liquid contained and isolated from non-hazardous coolant systems
Standard Components	<ul style="list-style-type: none"> • Pump • Base • Flexible coupling • Coupling guard • TEFC motor 	<ul style="list-style-type: none"> • Pump • Base • TEFC motor/drive • Seal water accessories: solenoid valve, flow control valve and strainer • Water trap silencer 	<ul style="list-style-type: none"> • Pump • Base • TEFC motor/drive • Seal water accessories • ASME-coded separator with sight glass • Heat exchanger • Automatic makeup system

Other NASH Products

TC/TCM

Integral 2 stage liquid ring pumps with improved performance at vacuum levels down to 0.8" HgA (27 mbar)
Designed to handle large amounts of liquid carryover without difficulty
Capacity of 100 to 2,240 CFM with vacuum to 0.8" HgA
Capacity of 170 to 3,740 m³/h with vacuum to 27 mbar abs



Steam Jet Ejectors

Sizes range from one-inch (25mm) to 78-inch (2 meters) inlets
Capacities range from 20 to 20,000 CFM
Capacities range from 34 to 34,000 m³/h
Multi-stage system pressures as low as 0.001 mm HgA



2BE4/P2620

Large liquid ring vacuum pumps with superior corrosion resistance
Top discharge capability which eliminates need for trench
Self-recirculating seal water, reducing need for external seal water source
Capacity of 4,000 to 23,000 CFM with vacuum to 24" HgV
Capacity of 6,800 to 39,000 m³/h with vacuum to 200 mbar abs



Service

We have the know-how, the expertise and the specialists. We provide professional service to make your pumps run for decades. Our service centers are located in:

- Australia
- Brazil
- China
- Germany
- Korea
- Netherlands
- Singapore
- South Africa
- Sweden
- UK
- USA



Compressors

Wide range of liquid ring compressors designed for many applications. Rugged and reliable, they can handle highly toxic, explosive and corrosive gases
Specifically developed for applications such as flare-gas, Chlorine and Vinyl Chloride Monomer (VCM) recovery
Capacity of 60 to 2,200 SCFM with pressure to 200 PSIG
Capacity of 100 to 3,740 m³/h with pressure to 15 bar abs
Single and two stage models available



NASH

Div. of Gardner Denver

9 Trefoil Drive
Trumbull, CT 06611 U.S.A.
phone: 800 553 NASH
+1 203 459 3900
fax: +1 203 459 3988
nash@gardnerdenver.com
www.GDNash.com

