

## NASH NRV-0200 & 0300

### OIL-LUBRICATED ROTARY VANE VACUUM PUMP

Rotary vane pumps operate by expanding volume at the inlet and compressing that volume at the exhaust. This is accomplished by placing the rotor eccentrically inside of the cylindrical housing, such that it is nearly touching the housing at the top, and is distanced from the bottom, as can be seen in the graphic. This rotor houses the vanes, and when it spins, centrifugal force causes these vanes to be slung out of the grooves they sit in until they contact the cylinder wall.

When the vanes are in this extended position, they create an effective gas barrier that splits the pump cavity into multiple sections. As they rotate, the sections exposed to the inlet port will continually be expanding, and the sections exposed to the exhaust port will continually be contracting. This causes the process gas to be drawn into the inlet, compressed within the pump, and expelled out the exhaust port.

NRV		0200	0300
Nominal Capacity	acfm	141	212
Ultimate Vacuum	Torr	0.375	
Nominal Motor Power	hp	7.5	10
Average Noise Level	dB(A)	71	72
Weight	lbs	347	385
Oil Capacity	qt	6.0	6.5

acfm\* Relates to pump inlet conditions.

Curves, table contents (tolerance  $\pm 10\%$ ) refer to vacuum pump at normal operating temperature.

The motor dimensions as well as the full load amperage may vary because of different motor manufacturers.

Technical information is subject to change without notice.



# DIMENSIONS

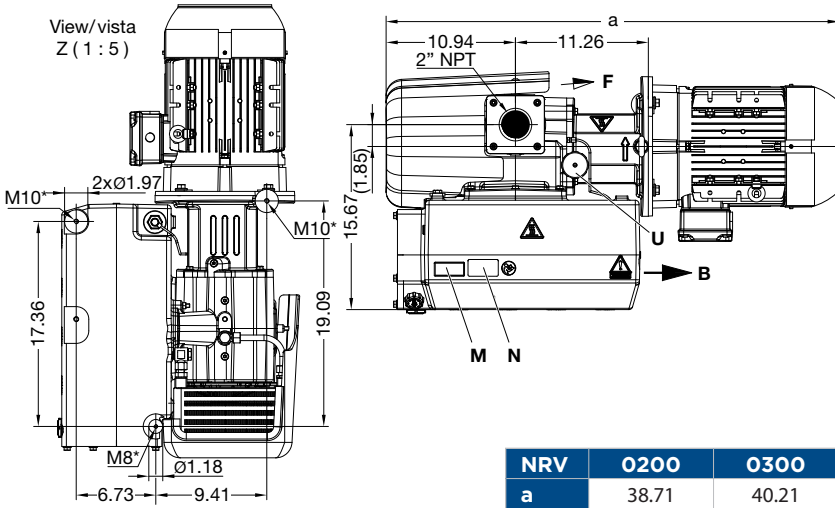
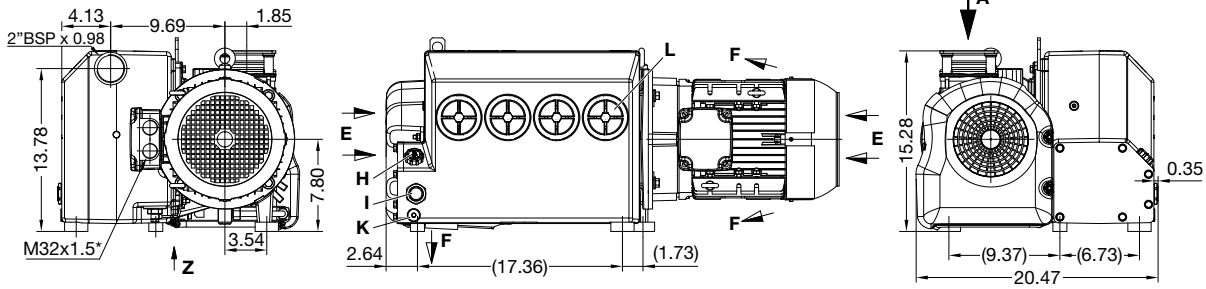

<b>K</b>	Oil drain point
<b>L</b>	Oil separator element
<b>M</b>	Oil type plate
<b>N</b>	Data plate
<b>O</b>	Rotation direction plate
<b>U</b>	Gas ballast valve

<b>A</b>	Vacuum connection
<b>B</b>	Exhaust
<b>E</b>	Cooling air entry
<b>F</b>	Cooling air exit
<b>H</b>	Oil fill
<b>I</b>	Oil sight glass

NRV	0200	0300
a	38.71	40.21

# PERFORMANCE CURVE

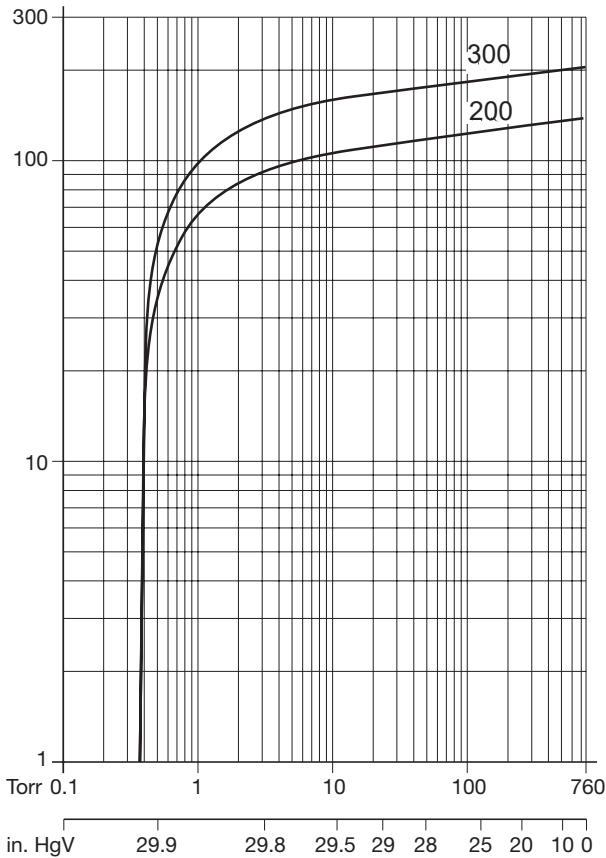

An Ingersoll Rand Business

[www.GDNash.com](http://www.GDNash.com)

©2021 Gardner Denver Nash, LLC Printed in U.S.A.  
GDN-MB-NDRV202303-1277 2nd Ed. 11/2022

